

Description: **Auto-Dimming Rearview Mirror with Compass** Part Number: **990B0-35007**

Applications: **SX4 Hatchback, 2007- SX4 Sedan, 2008-** Installation Time: **.5 HRS**

## Contents

Ref.	Part Number	Description	QTY
1.	990B0-35007	Auto-Dimming Mirror with Compass	1
2.	990B0-35007-001	Hardware Kit	1

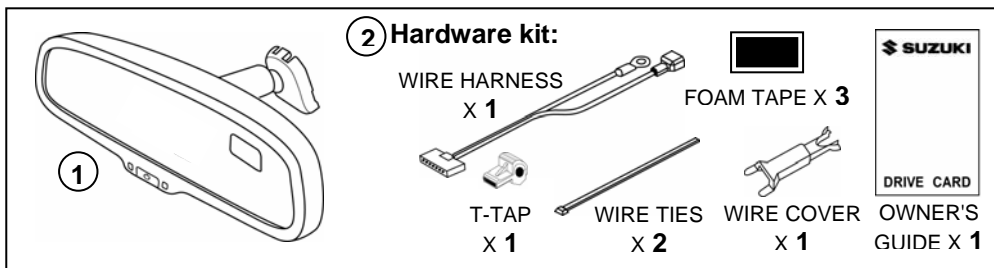

## Tools Required

Ref.	Tools Description
1.	4mm Flat Screwdriver
2.	Panel Removal Tool
3.	Needle-nose Pliers
4.	Ratchet and 10mm Socket
5.	#T20 Torx Driver
6.	Side-Cutters
7.	Dark Towel or Cloth **
8.	Torque Wrench **

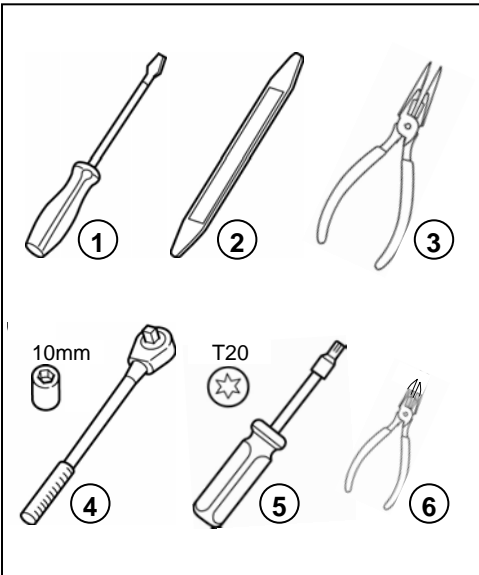

\*\* Not Shown

## Important

**WARNING CAUTION**

Please read and follow the instructions carefully. To emphasize special information, the symbol and the words, "**WARNING, CAUTION** and **NOTE**" have special meanings. Pay special attention to the message highlighted by these signal words.

### NOTE

**Note:** *Indicates special information to make maintenance easier or instructions clearer.*

## WARNING

Indicates potential hazard that could result in personal injury.

## CAUTION

Indicates potential hazard that could result in vehicle damage.

## Preparation Prior to Installation

1. Disconnect vehicle's negative battery cable (See Figure 1).

### WARNING

Do not touch the positive terminal with any tool when removing the negative battery cable.

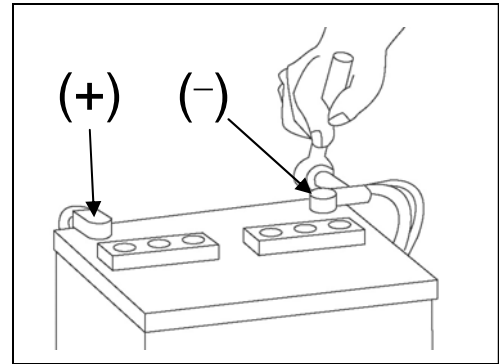

Figure 1

2. Remove driver side cowl cover (See Figure 2).
  - a) Grasp cowl cover at rear and pull towards rear of vehicle.

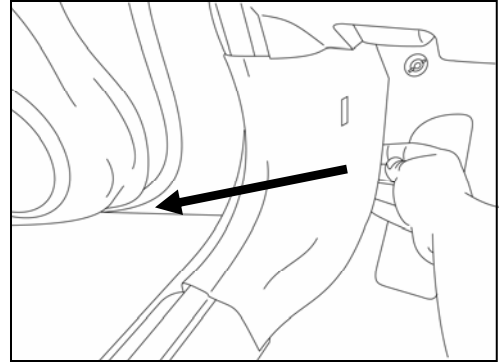

Figure 2

3. Partially remove driver side door seal (See figure 3).
  - a) Grasp inside edge of door seal at A-pillar, and pull downward to allow for removal of A-pillar trim and cowl cover.

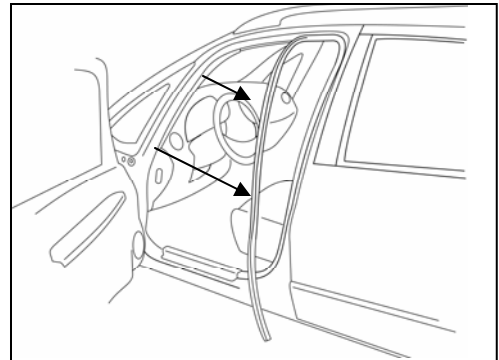

Figure 3

4. Remove driver side front A-pillar trim piece (See figure 4).
  - a) Using panel removal tool, disengage top of front A-pillar trim.
  - b) Grasp top of trim piece and pull towards rear of vehicle to remove.

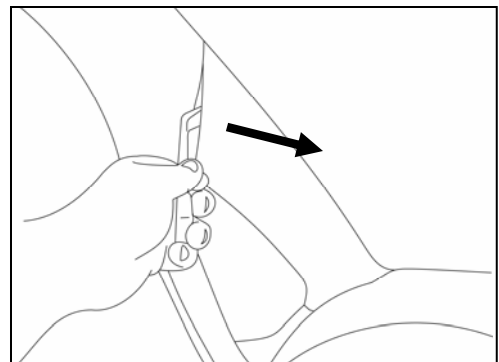

Figure 4

**GENUINE SUZUKI ACCESSORIES**

5. Complete removal of A-pillar trim  
(See figure 5a).

- a) Using ratchet, remove the 10mm bolt, securing trim piece.

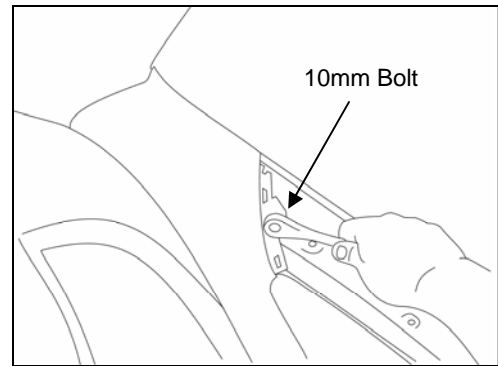

Figure 5a

- b) Pull top of trim piece away from A-pillar and then pull towards the rear of the vehicle to remove (See figure 5b).

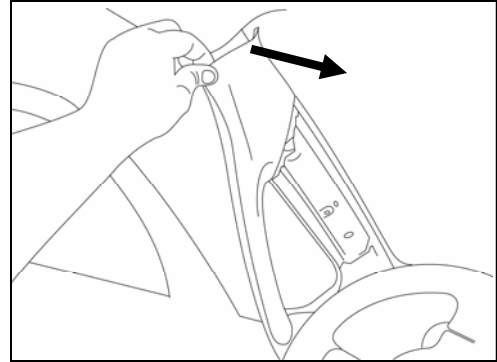

Figure 5b

**NOTE: For Hatchback vehicle's, skip to step 8.**

**For Sedan vehicle's, proceed to step 6.**

6. Remove the column cover by removing the two screws and gently pulling to free the clips and tabs (See figure 6).

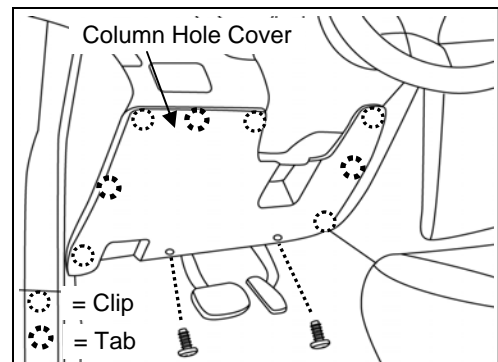

Figure 6

7. Locate and remove Body Control Module.

- a) Using a 10mm ratchet, remove the two bolts securing the Body Control Module. Release three separate connectors on back. Set the pieces aside (See figure 7a).

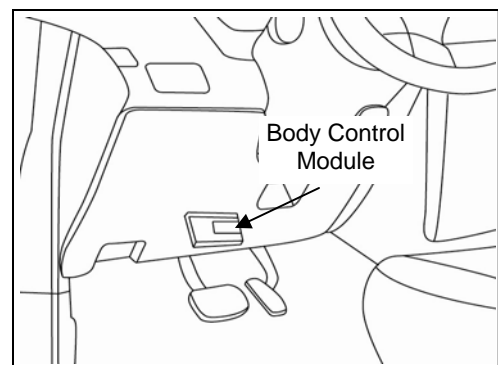

Figure 7a

**GENUINE SUZUKI ACCESSORIES**

- b) Backside view of the Body Control Module (See figure 7b).

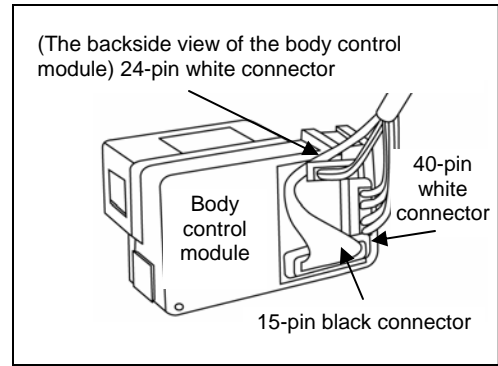

Figure 7b

- 8. Using a panel removal tool, remove the factory mirror by gently prying back on the locking tab at the bottom of the mount while wiggling the mirror upwards off from the windshield mounting button (See figure 8).

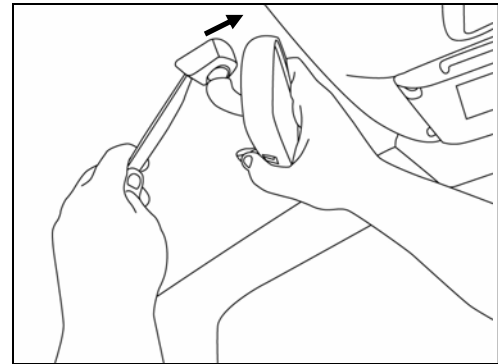

Figure 8

**CAUTION**

Do not pry back against windshield button as damage may result.

**Installation**

- 1. Slide auto-dimming mirror onto windshield button, ensuring that it is fully seated (See figure 9).
  - a) Tighten the T20 torx screw in the auto-dimming mirror mount to 1.1 - 1.4 ft-lbs (15.2 - 20.3 kg-cm or 1.5 - 2.0 N-m).

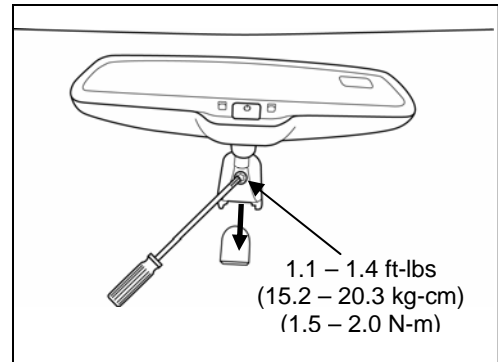

Figure 9

**CAUTION**

Ensure mirror mount screw is tightened to specification to prevent rattling of mirror.

- 2. Plug 7-pin connector of auto-dimming mirror harness into back of mirror (See figure 10).

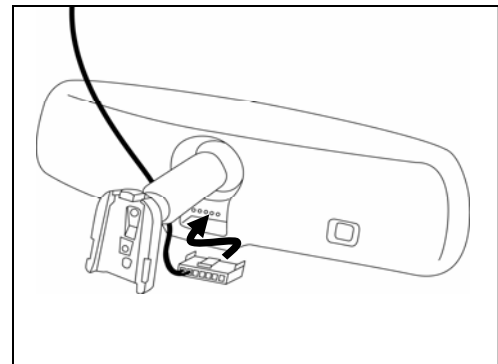

Figure 10

**GENUINE SUZUKI ACCESSORIES**

3. Attach wire cover to base of mirror, covering harness wires (See figure 11).

- a) Slide upper portion of wire cover up to headliner so the "forks" are held by the headliner.

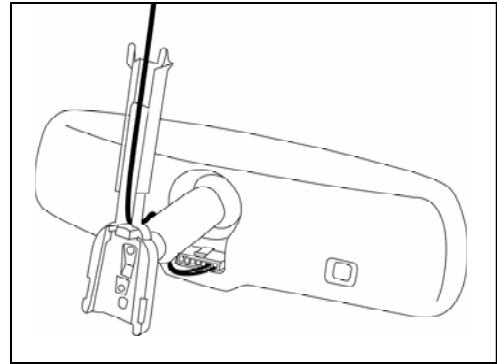

Figure 11

4. Route auto-dimming mirror harness between headliner and roof to the top of the driver side A-pillar. Continue routing harness down A-pillar (See figure 12).

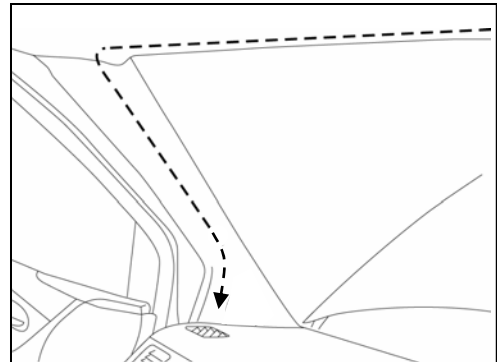

Figure 12

5. Tear each of the 3 pieces of foam tape in half (see figure 13).

**NOTE: All 6 half-pieces of foam tape will be used during installation.**

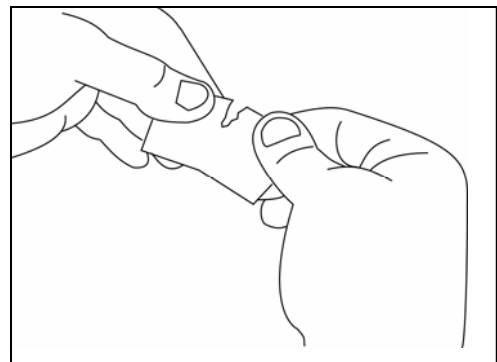

Figure 13

6. Route mirror harness down A-pillar as shown, securing with foam 5 half pieces of foam tape in the locations shown (See figure 14).

**CAUTION**

Do not block any fastener openings with foam tape.

**WARNING**

Do not secure harness to airbag or in any way impede airbag operation.

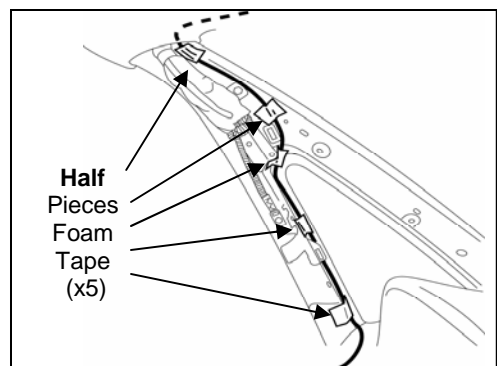

Figure 14

**GENUINE SUZUKI ACCESSORIES**

7. Route auto-dimming mirror harness along center dash, in opening between door trim and inner center dash (See figure 15).

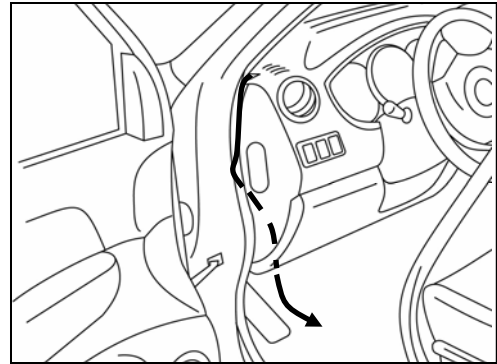

Figure 15

8. Secure harness inside center dash with 1 half piece of foam tape (See figure 16).

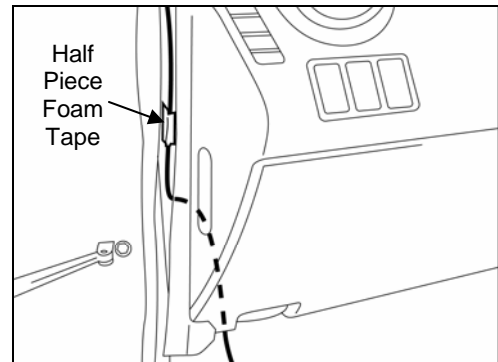

Figure 16

9. Pull individual wires apart from auto-dimming mirror harness, approximately 6 inches (See figure 17).

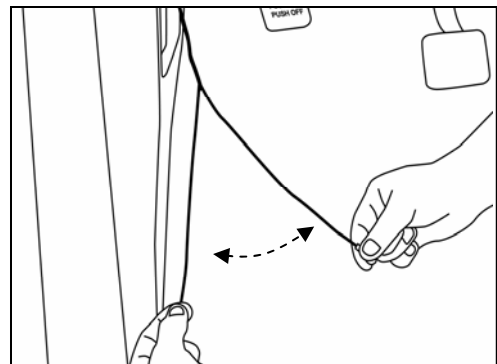

Figure 17

10. Locate the 10mm ground bolt behind the driver side cowl area and remove (See figure 18).

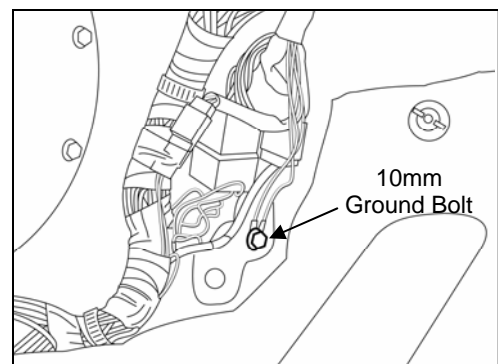

Figure 18

**GENUINE SUZUKI ACCESSORIES**

11. Attach ring terminal from auto-dimming mirror harness ground wire to the 10mm ground bolt and reinstall bolt (See figure 19).

**NOTE:** For Hatchback vehicle's, skip to step 15 for power to auto-dimming mirror.

**For Sedan vehicle's, proceed to steps 12 thru 14 for power to auto-dimming mirror.**

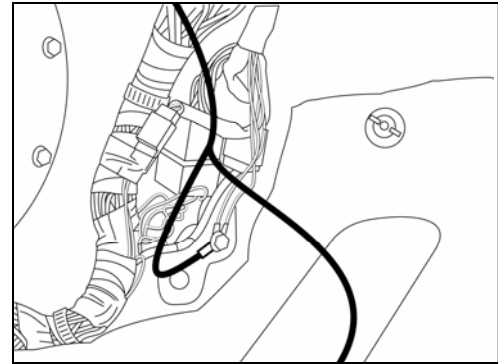

Figure 19

12. **SEDAN ONLY**  
Locate the wire junction box, against the driver side cowl. Locate the **White / Black-striped** wire and carefully cut the black tape using side cutters (See figure 20).

### CAUTION

Do not damage any vehicle wires while cutting back tape.

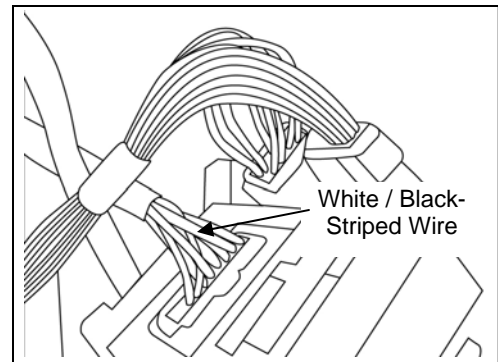

Figure 20

**NOTE:** This wire will provide the power to the auto-dimming mirror.

13. **SEDAN ONLY**  
Attach T-tap connector to White / Black-striped wire (See figure 21).

**NOTE:** Ensure both halves of T-tap connector are snapped together.

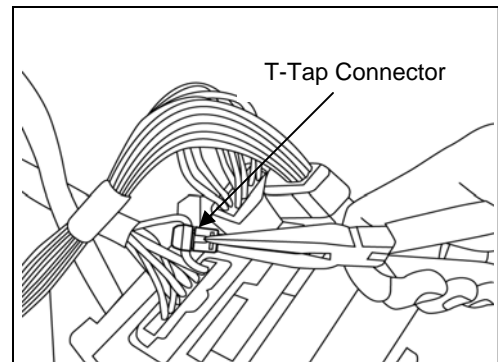

Figure 21

14. **SEDAN ONLY**  
Insert the spade terminal from auto-dimming mirror harness into spade connector (See figure 22).

**NOTE:** Ensure spade connector is fully inserted into T-tap.

**NOTE:** For Sedan vehicle's skip to step 19.

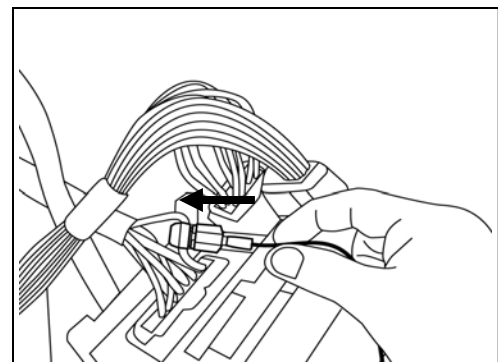

Figure 22

**GENUINE SUZUKI ACCESSORIES**

**15. HATCHBACK ONLY**

Using side-cutters, carefully cut back black tape on large wire bundle in cowl area, to gain clear access to wires (See figure 23).

**CAUTION**

Do not damage any vehicle wires while cutting back tape.

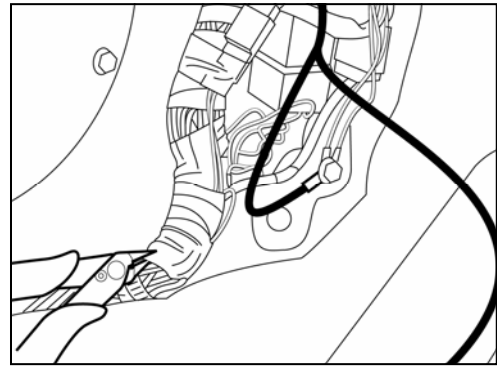

Figure 23

**16. HATCHBACK ONLY**

Locate the **White / Black-striped** wire in vehicle wire bundle. (See figure 24).

**NOTE: This wire will provide the power to the auto-dimming mirror.**

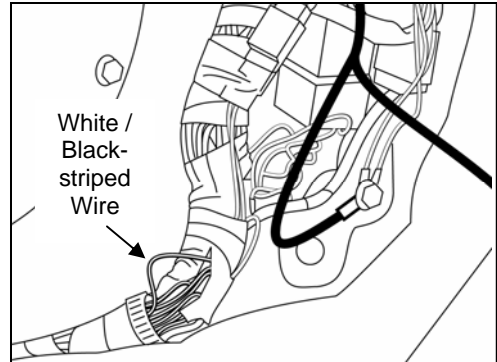

Figure 24

**17. HATCHBACK ONLY**

Attach T-tap connector to White / Black-striped wire (See figure 25).

**NOTE: Ensure both halves of T-tap connector are snapped together.**

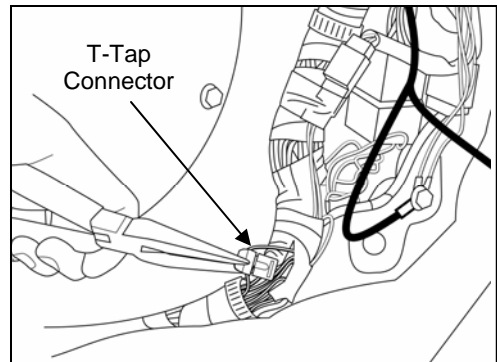

Figure 25

**18. HATCHBACK ONLY**

Insert the spade terminal from auto-dimming mirror harness into spade connector (See figure 26).

**NOTE: Ensure spade connector is fully inserted into T-tap.**

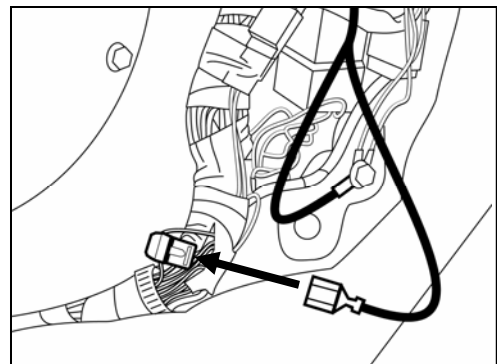

Figure 26

**GENUINE SUZUKI ACCESSORIES**



19. Bundle all excess auto-dimming mirror harness and secure with 2 wire ties in the locations shown (See figure 27).

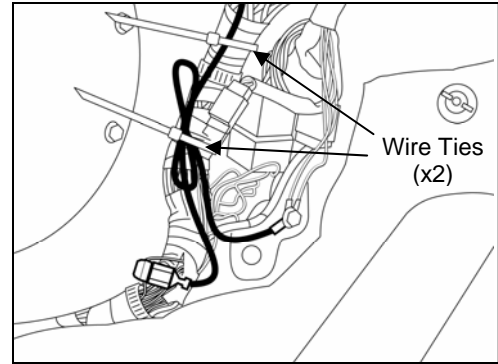

Figure 27

## Final Adjustment of Mirror

1. If required, adjust the mirror at Point 1 and Point 2 to allow clearance with the sunvisor and for proper driver stature (See figure 28).

**NOTE: Adjustment point 2 requires more force to move, than adjustment point 1.**

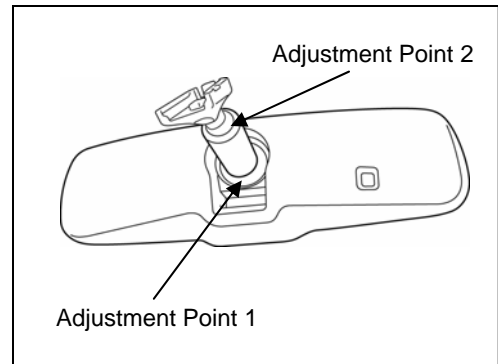



Figure 28

## Testing

1. Reconnect negative battery cable.
2. Turn the ignition switch ON.
3. With the vehicle in a fairly well-lit area, perform the following test:
  - a) To make sure the auto-dimming feature is on, verify that the green LED to the left of the center switch is on. If it is not on, push the  switch to turn the green LED on.
  - b) Cover the forward looking photocell on the back of mirror with a dark cloth or towel (See figure 29). In a few seconds, the mirror will begin to darken.
  - c) Remove the cover from the forward looking photo cell and the mirror will begin to clear.

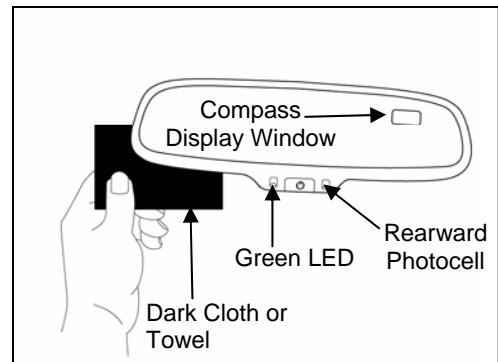



Figure 29

**GENUINE SUZUKI ACCESSORIES**

- d) Verify that either a direction, such as "NE", or "C" is displayed in the display window. If not, ensure the feature is turned ON by pressing the  switch.

**Testing is now complete.**

## Installation of Removed Parts

1. Trim excess off all wire ties.
2. Reinstall in reverse order, all trim pieces removed during installation.
3. Place User Guide in vehicle glove-box (See figure 30).
4. Remove fingerprints, smudges, dirt, etc. from mirror.
5. Verify each reinstalled component for proper fit and function.

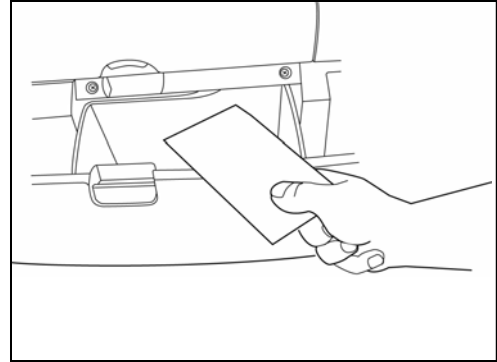

Figure 30

**GENUINE SUZUKI ACCESSORIES**

## Compass Zone Setting and Calibration

1. The zone setting is factory preset to Zone 8. Refer to Compass Calibration Zone Map to find correct compass zone setting for your geographical location (See figure 31).

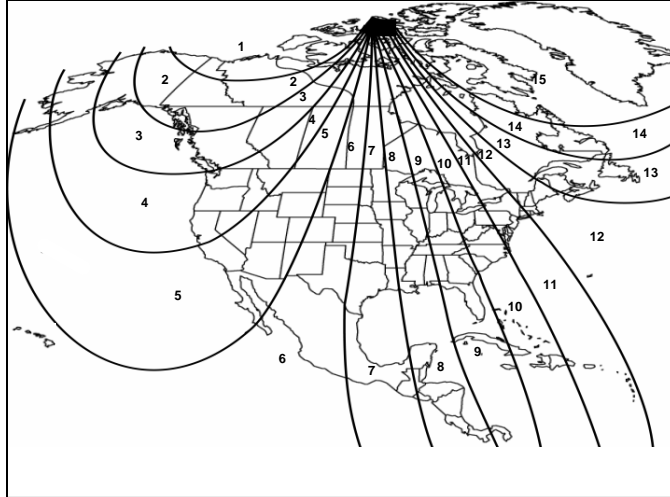



Figure 31

2. Drive to an open, level area, away from large metallic objects or structures.
3. Hold the  switch for approximately 9 seconds until "C" text appears in the display. Release the right button to enter the calibration mode.
4. Drive slowly in up to 3 circles until the "C" disappears, and a directional heading is displayed. The compass is now calibrated.

**GENUINE SUZUKI ACCESSORIES**